

# multicar

**NEW!**  
Now with a  
Euro 4 engine



## M 26

More than a Transporter

# Special Transporter with Implement Carrier Function

# The Classical Model with Euro 4 Engine

In municipalities, service contractors landscaping, building contractors, waste disposal companies and in many other areas: M 26 is at home wherever flexible transporter performance in a confined space is required.

With a gross vehicle weight rating of up to 4.8 t and three attachment areas for implements, the M 26 is a real multitalent providing powerful work performance.

The classical Multicar model works for you 365 days a year – in summer and winter. It is in its element in the pedestrian area as well as off-road. Thanks to four-wheel drive with differential lock and great climbing power, it handles even difficult terrain easily. With a width of only 1.59 m, it displays its strengths especially wherever large working vehicles do not fit in.



Depending on the application, you can decide in favour of the short or long wheelbase, an electrohydraulic tipper, for single-circuit or three-circuit hydraulics. You can also extend the capacity of the M 26 with an additional trailer. The powerful VM turbo diesel engine with 74 kW/100 HP, even when fully loaded, optimally applies its power to the task.

The M 26 gives you freedom of action for your decisions - today and also in years to come. Thanks to its modular construction, you can always adapt this sturdy special transporter to your changing requirements.

Discover the versatility and the favourable price/performance ratio of this extraordinarily compact special transporter.

Discover the M 26.



## Compact and Manoeuvrable

With a height of only 2.24 m, a width of 1.59 m and a turning radius of 4.9 m (depending on the version), the M 26 is the ideal partner for paths, pedestrian areas, narrow driveways and all other working areas where access is difficult.



## Variable in Use

The M 26 is a universal special transporter with many options: The proven front-end quick-hitch facility, powerful attachment points at the front, top and rear and three hydraulic variants.



## Strong and Tireless

The powerful 74 kW/100 HP VM turbo diesel engine develops its maximum torque of 270 Nm already at low speed. Thanks to its sturdy construction and, depending on variant and equipment, it has a gross combination weight rating of up to 4.8 t, a payload of up to 2.6 t and a braked trailer weight of up to 3.5 t.



## Modular and Moderately Priced

The M 26 is easy on your budget when you buy it and also a long time after. You can always adapt it to your requirements. Its proven modular vehicle concept gives you a high degree of freedom of action even in the future.

## Your advantage:

**Strong, dynamic and powerful. The Euro 4 engine provides full performance and is friendly to the environment.**

# Concentrated Working

High transport performance, powerful drive and a favourable price/performance relationship characterise the proven M 26 from Multicar. For many years, thousands of Multicar users have sworn by the continuously further developed concept of this special transporter. Its wide spectrum of application and its long service life offer the bases for reliable and flexible work performance, year in, year out.

## Specialist for Narrow Lanes and Difficult Terrain



**High Loading Capacity**

Whether a three-way tipper or a skip loader, the loading volume of the M 26 is extremely generous: Up to 2.5 m<sup>3</sup> for the skip loader and up to 1.3 m<sup>3</sup> for the three-way tipper. The chassis loading capacity of the specialised transporter is 3 t. Depending on equipment variant and axle load distribution, this means a payload of up to 2.6 t. With a trailer, you can even double its loading volume and thereby utilise its complete transport capacity.



**Traction also in the Terrain**

Thanks to its good traction quality and the 4x4 four-wheel drive, the M 26 masters even the most difficult terrain and slopes up to 32°. Especially on building sites and off-road, it thereby becomes an indispensable helper.



**Small Turning Radius**

With its compact exterior dimensions and its small turning radius of 4.9 m minimum, the M 26 is the ideal special transporter for narrow and impassable terrain. The easy-running and precise power steering supports manoeuvring, even in the most difficult situations.



**Sturdy Construction**

To perform powerful work for 365 days a year, a solid construction is needed. With its sturdy, torsion-resistant, steel profile framework in welded construction, the M 26 stands up to the strongest challenge. The load platform consists also of a solid steel construction which has proven itself day after day.



**Single-Circuit and Three-Circuit Hydraulics**

If you wish to use the M 26 in addition to the transporter function, also for operating stationary or mobile equipment, you should decide in favour of a model with single-circuit or three-circuit hydraulics. With up to 30 kW hydraulic power, the M 26 becomes a flexible equipment carrier.



**Quick-hitch system**

Make professional use of the M 26's implement-carrier characteristics. The patented ball & socket quick-change system, the forward-mounted quick-hitch system, and the standardised attachment points on the chassis frame guarantee easy handling of more than 100 attachments and superstructures offered by specialist tool manufacturers. Hitch up. Connect. Ready.

### Your advantage:

**The M 26 is the special transporter with additional implement carrier functions. Make your decision for professional transporter operations or for the additional operation of stationary or mobile implements.**

# Modern Technology

## Application-Oriented and Environmentally Aware

The M 26 is primarily a special transporter that wants to be, above all: Your working partner. It brings you quickly, comfortably and speedily to your destination, does its work in a powerful manner and brings you back safely. It works for you 365 days a year and saves your money with its long service intervals. You can rely on the M 26 for many years.

### Your advantage:

**A proven concept together with modern technology, this is the M 26! A special transporter you no longer want to be without.**



#### Environmentally Friendly with Euro 4 Turbo Diesel Engine

In a powerful and dynamic manner, the VM engine safely takes you to your destination with its 74 kW/ 100 HP and a speed of 3000 rpm. Thanks to Euro 4, electronic engine management, common-rail injection system, exhaust gas turbo charger, charge-air cooling and a closed-system particle filter, it always runs with low impact on the environment at up to 90 kph.



#### Exemplary Road Holding

The fully synchronised 5-speed gearbox is smooth and brings the power of the engine directly on the road. The rear axle drive and the standard rear twin wheels ensure the best road holding. If you do most of the work in the terrain, you should choose four-wheel drive. The switching in the crawler gear makes possible a minimum working speed of 0.6 kph.



#### Excellent Shock Absorption

Hydraulic telescopic shock absorbers, leaf springs and additional rubber springs at the front and rear ensure always driver-friendly road holding – in unloaded as well as fully loaded condition with up to 2.6 t payload.



#### Braking Safely, also in Dangerous Situations

The hydraulic two-circuit brake and the vacuum power brakes bring the M 26 to a quick standstill even in problem situations. The automatic brake control systems remind you in time of exchanging the corresponding worn parts and thereby round off the safety concept.



#### Service Friendliness

The M 26 is working for you all year round. Long service intervals, good access to the technical system of the vehicle and simplest diagnosis make it so service friendly. Combined with the high quality of the individual assemblies, the M 26 ensures economic performance over many years.

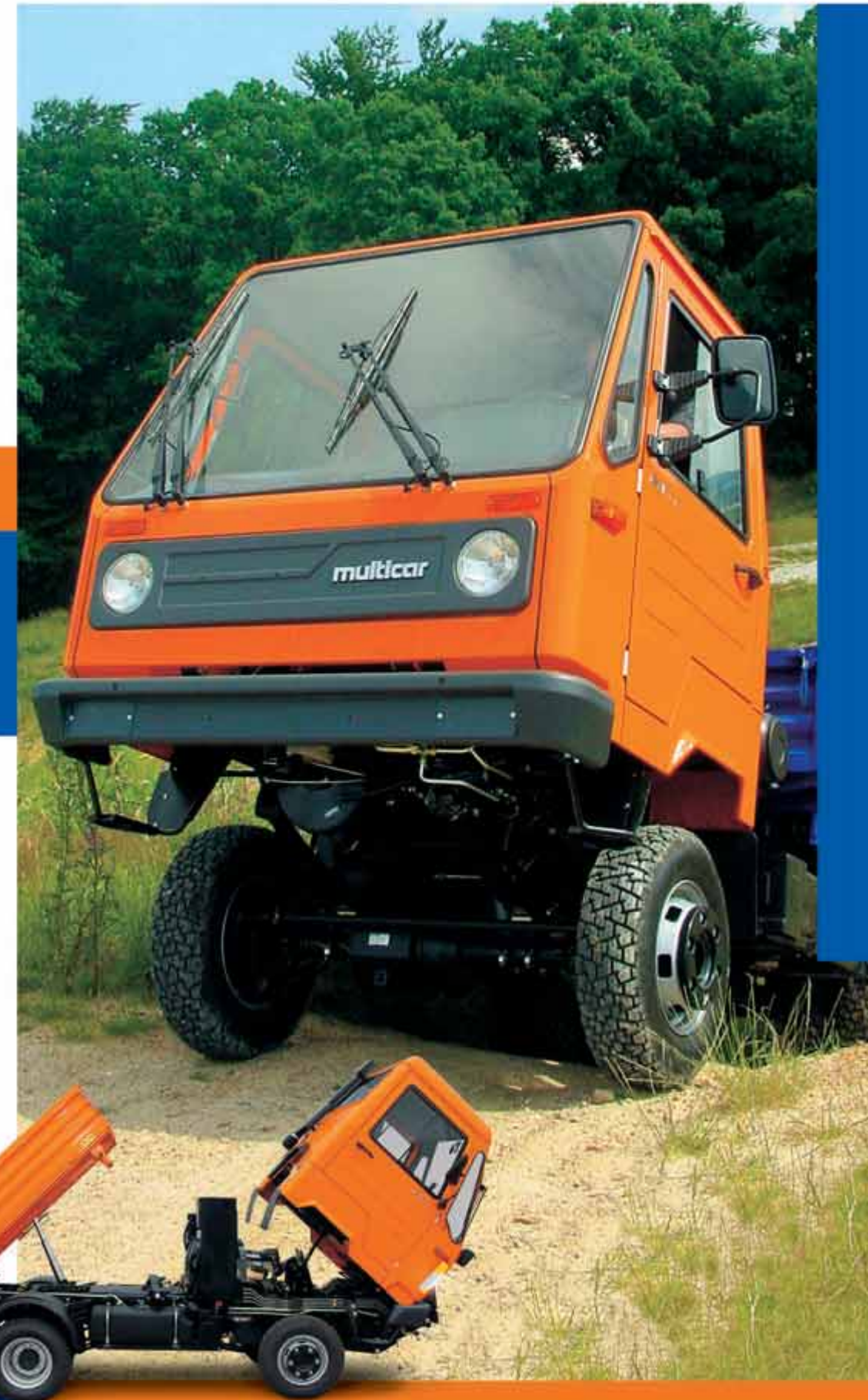

# Modular Selection

The M 26 is based on a modern, modular vehicle concept which, even years after the purchase, leaves all paths open to you. No matter which basic model you select today, you always have the choice between a short and a long wheelbase, between 4x2 and 4x4 drive with crawler gear and between at least 20 optional equipment modules. Later, you have many opportunities for reequipping.

## For Individual Tasks

**Your advantage:**

**Choose yourself! Your requirements profile is decisive for the selection of the carrier vehicle. We will be pleased to help you.**

### M 26 TRANS LINE

**Special Transporter with Three-Way-Tipper**

The M 26 TransLine three-way dumper is the special transporter for professional transporter applications. With electrical tilting hydraulics and a payload of up to 2.6 t, it is the ideal partner for variable use on building sites and in the terrain. With a shackle-type hitch or ball coupling, you extend its transport volume again with a suitable trailer.



### M 26 TRANS LINE

**Special Transporter with Skip Loader**

The M 26 TransLine skip loader is the special transporter for professional disposal operations. With stationary single-circuit hydraulics and a payload of up to 2.3 t, it is the ideal partner for variable use on roads and in the terrain. Also with this model, you can extend your transport capacity decisively with a suitable trailer.



### M 26 ECO LINE

**Special Transporter with Single-Circuit Hydraulics**

If you also wish to operate stationary equipment in addition to the strong transporter performance of the M 26, the M 26 EcoLine offers you the suitable standard equipment. With 200 bar operating pressure, you can operate a loading crane, a refuse compactor or a platform lift, for example, and thereby extend your application spectrum decisively.



### M 26 PROFI LINE

**The Implement Carrier among the Special Transporters**

The mobile universal hydraulics of the M 26 ProfiLine provide you with a wide spectrum of applications. You make use of the strong transporter capacity of the M 26, and this with the full implement performance. More than 100 possible implements and attachments support you in summer and winter use: from the snow plough and the high-pressure washing system to the wood shredder and the mower. The M 26 ProfiLine makes possible the optimised application with changing implements every day.



# Inspiring Technology

## Engine and Gearboxes:

Engine:	VM R 754
Displacement:	2970 cm <sup>3</sup>
Power:	74 kW (100 HP) with 3000 rpm
Maximum torque:	270 Nm with 1400 rpm
Emission of pollutants:	Euro 4 with a closed-system particle filter
Gearbox:	5-speed, fully synchronised, with four-wheel drive including splitter gearbox

## Drive and Control:

Drive:	4x2, alternatively 4x4
Clutch:	Hydraulically operated, free from asbestos
Steering:	Power steering
Tank volume:	70 l
Brakes:	Hydraulic two-circuit system, disc brake at the front, drum brake at the rear

## Load Values:

Wheelbase:	2100, alternatively 2675 mm
Gross weight rating (increased gross weight rating):	4.3 t (4.8 t)

	M 26 TransLine	M 26 TransLine, Skip Loader
Payload with 4.3 t gross weight with 4x2 drive and short/long wheelbase up to*	2.1 t/2.0 t	1.8 t (only with short wheelbase)
Payload with 4.3 t gross weight with 4x4 drive and short/long wheelbase up to*	2.0 t/1.9 t	1.7 t (only with short wheelbase)
Payload with 4.8 t gross weight with 4x2 drive and short/long wheelbase up to*	2.6 t/2.5 t	2.3 t (only with short wheelbase)
Payload with 4.8 t gross weight with 4x4 drive and short/long wheelbase up to*	2.5 t/2.4 t	2.2 t (only with short wheelbase)

The load values for M 26 EcoLine and M 26 ProfiLine vary depending on the attachment.

\*Additional implements reduce the payload.

Gross trailer weight:	3.5 t
Gross combination weight rating:	6.7 t

## Your advantage:

**A proven concept. Plus Powerful performance. Multiplied with manoeuvrability. Exponentiated with an excellent price/performance relationship. Equals: M 26, an investment that pays for itself!**

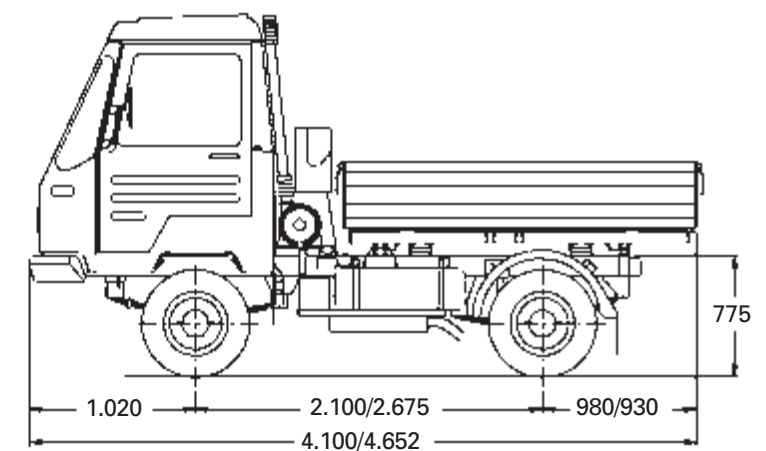
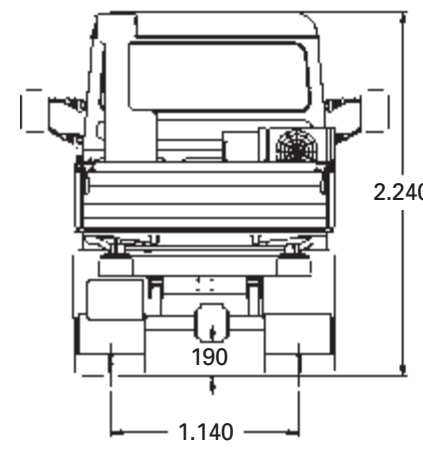
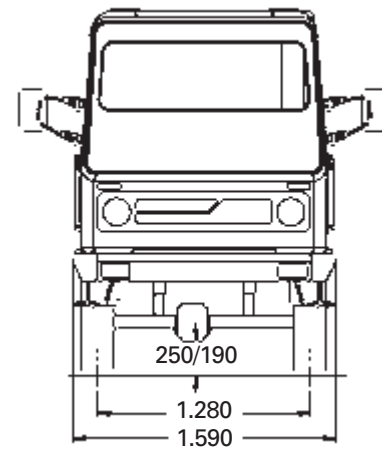

The second value is for vehicles with 2675 mm wheelbase

# Basic Data for Economic Performance

## Driving qualities:

Chassis:	Torsion-resistant light-profile steel frame			
Front axle/suspension:	Rigid axle, leaf spring with additional rubber spring and telescopic shock absorber			
Rear axle/suspension:	Rigid axle, leaf spring with additional rubber spring and telescopic shock absorber			
Tyres:	195 R 14 C 8PR, rear axle with twin tyres			
Brake:	Hydraulic two-circuit brake with vacuum power brakes			
Cab:	Tilting 2-person comfort cab			

	M 26 TransLine	M 26 TransLine/Skip Loader	M 26 EcoLine	M 26 ProfiLine
Maximum driving speed:	90 kph	90 kph	90 kph	90 kph
Maximum working speed:	-	-	-	0.6 – 90 kph

Hydraulics:	M 26 TransLine	M 26 TransLine/Skip Loader	M 26 EcoLine	M 26 ProfiLine
	max. l/min; max. operating pressure/bar	max. l/min; max. operating pressure/bar	max. l/min; max. operating pressure/bar	max. l/min; max. operating pressure/bar
Electrical tipping hydraulics:	5; 150	-	-	-
Stationary single-circuit hydraulics:	-	45; 200	45; 200	-
Mobile three-circuit universal hydraulics:	-	-	-	90; 200

## Optional comfort equipment:

Trailer coupling, trailer towing device, lifting sunroof, heated front windshield, etc.

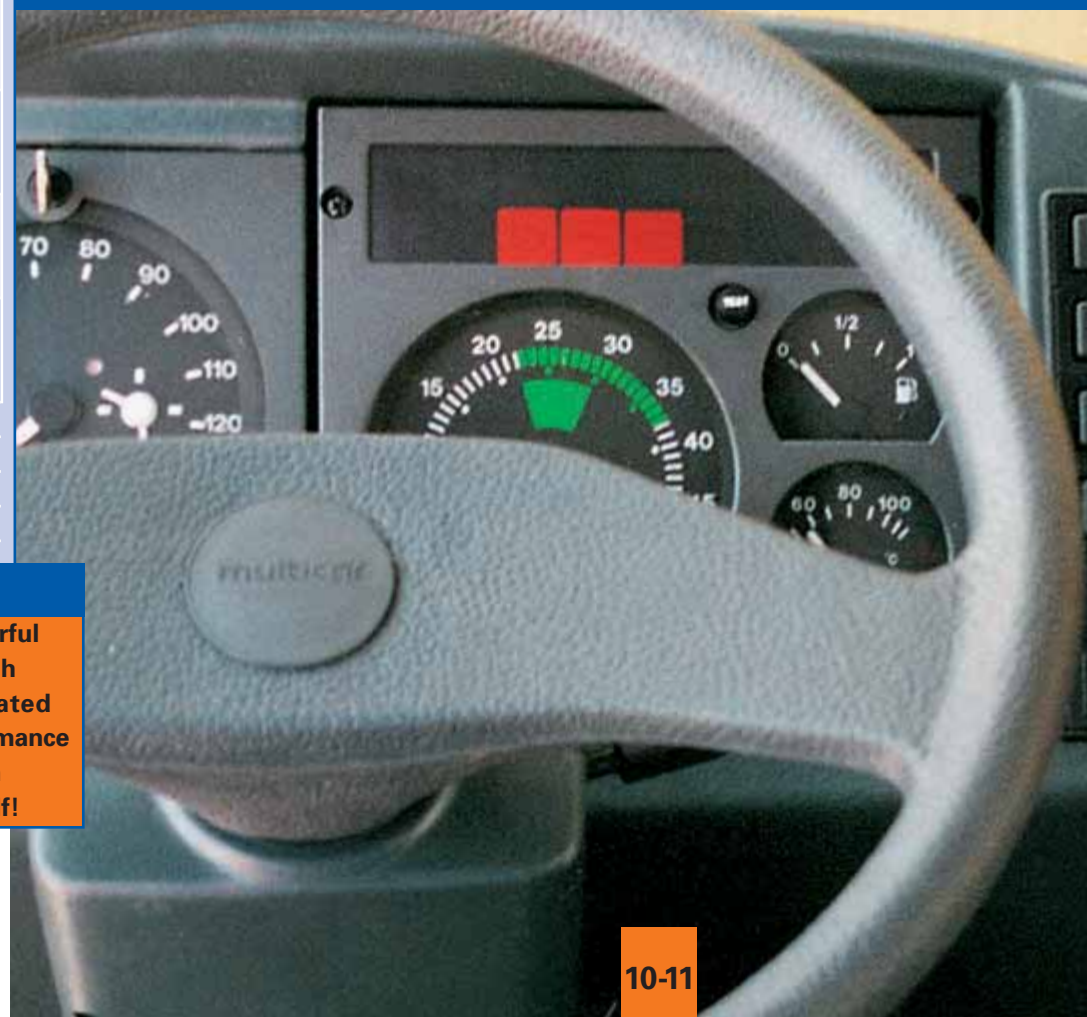



You can count on Multicar.

**Before you buy:**

Assistance by trained employees.

**While you buy:**

Fair price/performance relationship.

**After you buy:**

Customer service near you.

Long-life MULTICAR quality.

Spare parts guarantee with 24-hour delivery service.

Speak with us.



**multicar**

Hako-Werke GmbH • product sector  
compact implement carriers and  
transport vehicles  
Industriestraße 3  
D-99880 Waltershausen  
☎ +49 (0)3622-640-0  
☎ +49 (0)3622-640-304  
info@multicar.de  
www.multicar.de